

MASONEILAN[®]

84000 Series

GT4000
07/04

STEAMFORM[®]

***Steam
Conditioning
Valve***



**INSTALLATION
GUIDE**

DRESSER[®]

TABLE OF CONTENTS

Masoneilan 84000 Series SteamForm Installation	1
Piping System Layout	1
Upstream Pipe Recommendations	1
Downstream Pipe Recommendations	2
Straight Pipe Length	2
Temperature Sensor Location	2
Pressure Sensor Location	3
Pipe Size and Selection	3
Material Break Point	4
Spray Water System Requirements	4
Water Pressure	4
Water Temperature	5
Strainers	6
Valve Installation	6
Valve Support	6
Actuator Support	6
Orientation	7
Drains and Pipe Slopes	8
Warm-up and Preheating Steam	9
Insulation	10
Accessibility	10
Temperature Control Methods	10
Temperature – Feedback Control	10
Temperature – Feedforward Control	10
Response Time and Stroke Speed	10
Start-up and Commissioning	11
System Blow Down and Cleaning	11
Post Weld Heat Treatment and Hydro-Testing	11
SteamForm Assembly	11
Commissioning Spares	11
Turbine Bypass to Condenser Applications	12
Bypass System Requirements	12
Process Control	12
Back-Pressure Dump Tubes	12
System Noise Evaluation	12
Final Recommendations	12

TABLE OF FIGURES

Figure 1	
Recommended Upstream Straight Pipe Length1
Figure 2	
Typical Downstream Piping Installation2
Figure 3	
Recommended Pipe Length Prior to the Temperature Sensor.3
Figure 4	
Evaporation Process of a Water Droplet4
Figure 5	
Recommended orientation of the SteamForm7
Figure 6	
Improper Orientation of the SteamForm7
Figure 7	
Vertical Flow Down Outlet Orientation, Drain Should be Located at Low Point Downstream .	.8
Figure 8	
Vertical Flow Up Inlet Orientation, Drain Should be Located at Low Point Upstream8
Figure 9	
Vertical Flow down Inlet Orientation, Drain Should be Located at Low Point of SteamForm Valve Body.9
Figure 10	
Horizontal Inlet and Horizontal Outlet Orientation, Drain Should be Located at Low Point of SteamForm Valve Body.9
Figure 11	
Start-up Trim.11

Masoneilan 84000 Series SteamForm Installation

Installation of the Masoneilan 84000 series SteamForm products requires a thorough understanding of the surrounding operating environment. Product selection and evaluation must extend upstream and downstream to ensure proper design for successful long-term operation. Masoneilan's installation guidelines are intended to provide recommendations and warnings for the various design elements of the steam conditioning system. Enhancements to the overall performance of the system are tested and documented through years of installed experience and proven field-tested methods.

Piping System Layout

The design and layout of the piping system are important factors for a successful installation of a steam conditioning valve. Several performance factors are highly dependent upon the proper arrangement of the piping system. Without the correct design in place, the steam conditioning valve becomes ineffective in achieving temperature control and stability. Additional Design requirements including selecting pipe size, laying out upstream and downstream piping, and positioning of control elements are explained throughout this document.

Upstream Pipe Recommendations

Adjacent pipe bends such as pipe elbows and tee connections are known to cause high levels of rotational forces and excessive vibration when installed in close proximity to a valve body. Long-term exposure to this flow induced vibration results in problems such as damaged trim and excessive noise during operation.

To reduce these risks, a uniform and stable flow profile must be achieved prior to admission of the steam into the SteamForm valve body. This is accomplished by supplying a length of straight pipe, L1, upstream of the valve inlet as shown in Figure 1. A straight pipe section allows the inlet steam to recover its uniform flow profile after passing through the turbulent path of an elbow. In the case of an upstream elbow installation, the recommended distance of five pipe diameters of straight pipe must be mounted upstream of the valve. Longer lengths of straight pipe are also desirable.

Upstream tee connections involve further consideration, as higher levels of turbulence are present in these applications. These systems must supply a longer length of upstream straight pipe, as higher levels of instability exist. Consult your local Masoneilan sales office or factory for the recommended distance for these applications.

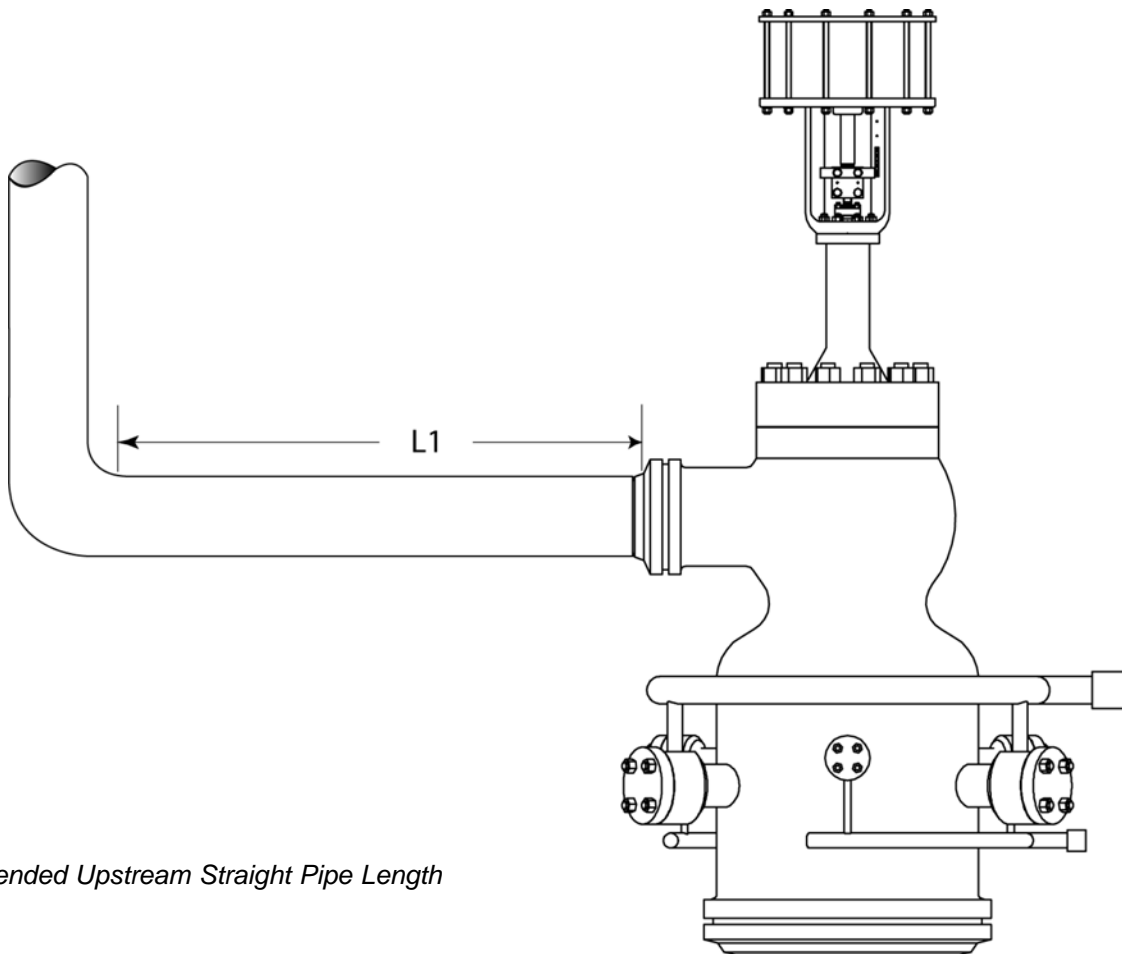

Figure 1:

Recommended Upstream Straight Pipe Length

Downstream Pipe Recommendations

Downstream considerations are more complex due to a larger number of variables that are introduced in the outlet of the SteamForm. The most significant of these variables includes the addition of spray water into the steam flow and the expansion of steam as the pressure is reduced. The following sections describe the necessary features for properly designing the downstream piping layout.

Straight Pipe Length

To avoid phase separation and downstream problems, such as erosion or poor process control, it is necessary to extend the straight pipe length exiting the SteamForm to allow for water vaporization prior to the installation of a pipe elbow. This distance ensures that a sufficient mass of the water droplets is vaporized in order to prevent water fallout and insufficient mixing. While this length varies with each set of design conditions, a

conservative design includes ten diameters of straight pipe, L2, downstream of the valve prior to installation of the first pipe elbow.

Once a minimum straight distance is obtained, Masoneilan recommends installing downstream elbows to enhance flow turbulence. The downstream elbows assist in the mixing of spray water within the steam flow and help achieve an evenly distributed temperature profile. It is suggested to design the first pipe bend using a long-radius, chrome-moly elbow to protect against wear and erosion. An example installation is shown in Figure 2.

Temperature Sensor Location

The temperature sensor must be located at a point far enough downstream to ensure 100% vaporization of the water droplets. For control stability, single-phase steam flow must be achieved. If high-energy water droplets exist within the steam flow, the temperature element recognizes sub-saturated conditions and reduces the capacity of water injection. This misplacement of the temperature element results in uncontrollable operation requiring re-engineering to correct the errors of the improperly designed steam conditioning system.

The proper location of the temperature sensor is application specific. Benefits from a properly designed downstream pipe system allow for a greatly reduced distance. Flow induced benefits are achieved with the proper placement of pipe elbows that allow high-energy turbulence to assist in the mixing of spray water upon passage through the elbow. For the sensor location of a specific application, a piping layout along with operating conditions must be provided to your local Masoneilan factory representative.

In some cases, the required distance prior to a temperature sensor cannot be provided by the plant due to a lack of real-estate or specific application requirements. In these cases, the use of a feedforward temperature control algorithm is required for control. See the temperature control methods that are explained later in this document for further explanation.

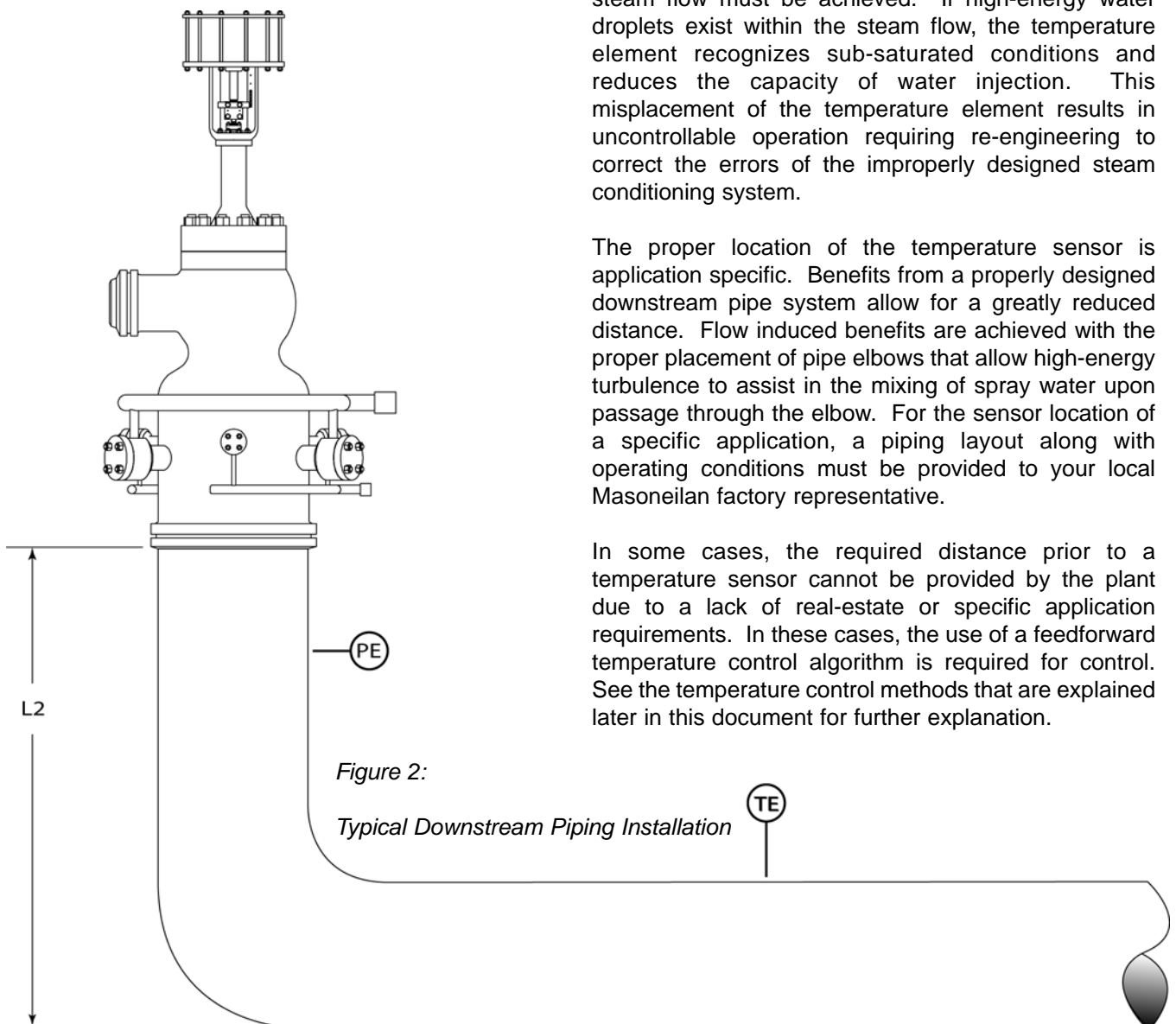
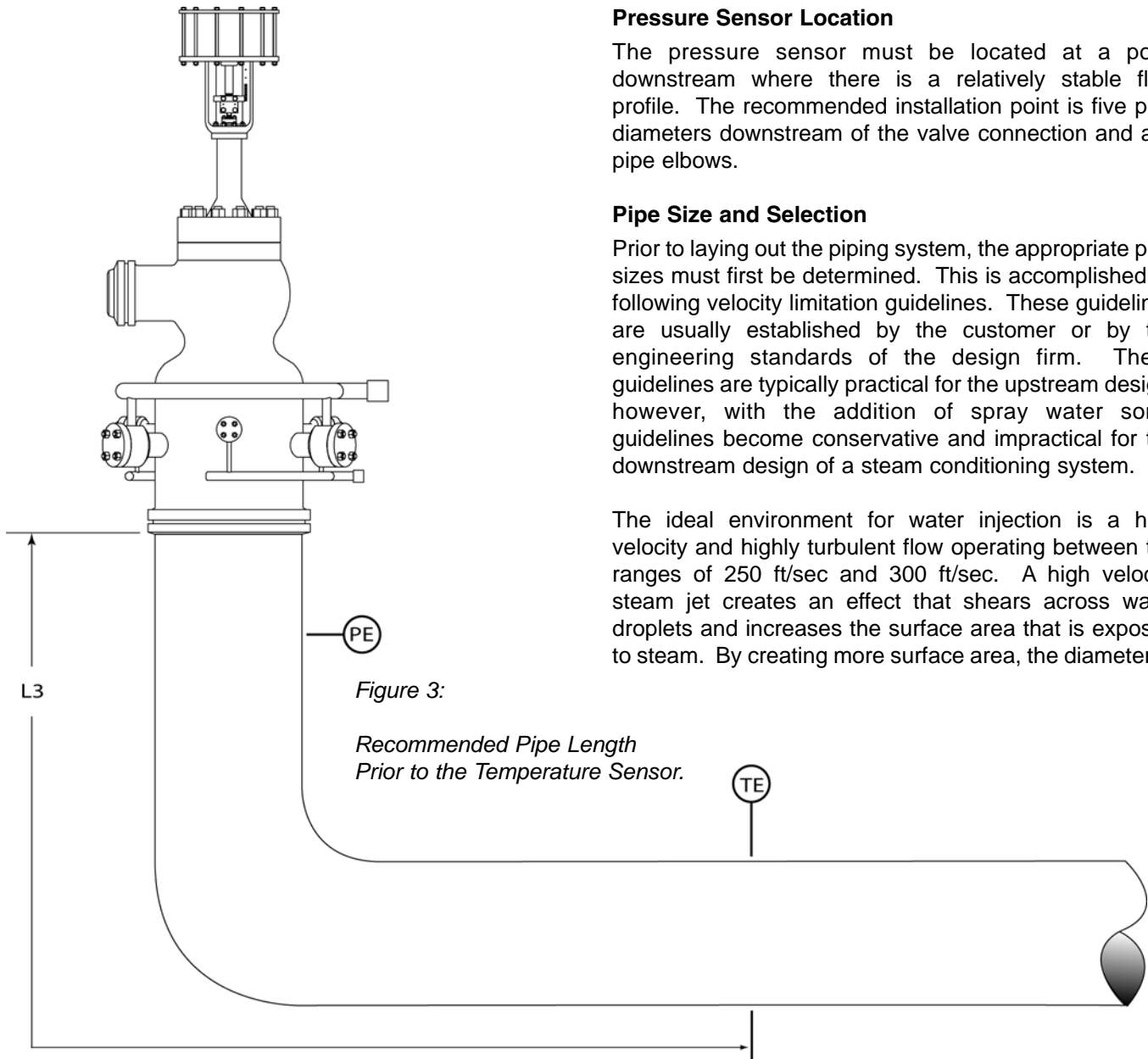

Figure 2:
Typical Downstream Piping Installation



Pressure Sensor Location

The pressure sensor must be located at a point downstream where there is a relatively stable flow profile. The recommended installation point is five pipe diameters downstream of the valve connection and any pipe elbows.

Pipe Size and Selection

Prior to laying out the piping system, the appropriate pipe sizes must first be determined. This is accomplished by following velocity limitation guidelines. These guidelines are usually established by the customer or by the engineering standards of the design firm. These guidelines are typically practical for the upstream design; however, with the addition of spray water some guidelines become conservative and impractical for the downstream design of a steam conditioning system.

The ideal environment for water injection is a high velocity and highly turbulent flow operating between the ranges of 250 ft/sec and 300 ft/sec. A high velocity steam jet creates an effect that shears across water droplets and increases the surface area that is exposed to steam. By creating more surface area, the diameter or

The radial location of the temperature sensor can be a concern for applications that do not pass through a pipe bend. Long lengths of straight pipe along with large quantities of water injection can result in spray water fallout. Thermal sensors located at or near the lower pipe wall can measure lower temperatures as water fallout reduces the temperature of the lower boundary layer at a faster rate than the pipe core. Temperature sensors must be placed in the middle to upper portion of the pipe cross-section to ensure the maximum steam temperature is observed.

As previously noted, the addition of at least one pipe elbow within a system is extremely beneficial in assisting with the mixing of spray water with the steam. These installations must always mount the temperature sensor downstream of the elbow by at least five pipe diameters. Close coupling of the sensor with an elbow can result in poor temperature control.

thickness of the water droplets is decreased. This drastically decreases the amount of time that is required for a water droplet to vaporize.

Conversely, a low velocity flow stream does not assist in breaking down the water droplet. As a result, larger diameter water droplets are injected into low velocity applications. Because these larger diameter droplets carry more mass, it becomes difficult at low velocity for the steam to suspend the heavier droplet in the flow stream. This can result in water fallout and insufficient evaporation at the temperature sensor location.

It is important to design the pipe around the most critical operating scenarios. For example, it is common to design a maximum flow rate scenario that is rarely ever experienced. For this case, it is beneficial to allow short durations of high velocity (in excess of 300 ft/sec) to obtain a tradeoff of better performance at lower flow

rates. There is a direct relationship between pipe size and turndown that must be evaluated for each installation.

After selecting the pipe size, the next step is to correctly design the pipe wall thickness and material to follow the appropriate codes of the country or state of the installation. The design of the downstream wall thickness and material depends on the upstream design temperature as a possible limit. This temperature limit is set because the water is introduced in the outlet of the valve, thus, does not effectively cool the steam until a significant distance downstream.

Material Break Point

As previously mentioned, temperature reduction does not occur immediately at the outlet of the SteamForm. Spray water injected into the steam must first heat-up to the saturation point, and then evaporate into steam for cooling. This phase change is shown in Figure 4. The SteamForm valve can be used as a material breakpoint, provided the lower grade material is designed to accept the full upstream temperature.

Multiple variables are presented in the calculation and are applied through indirect relationships. For applications where a temperature reduction must take place prior to the material downgrade, a Masoneilan factory representative should be contacted to provide the best location for the material transition.

Warning: Steam exiting the SteamForm valve exhibits high temperature. Complete cooling of the steam temperature does not occur until the spray water evaporates and mixes with the steam. Therefore, the final outlet set point is not achieved until reaching the factory specified temperature sensor location.

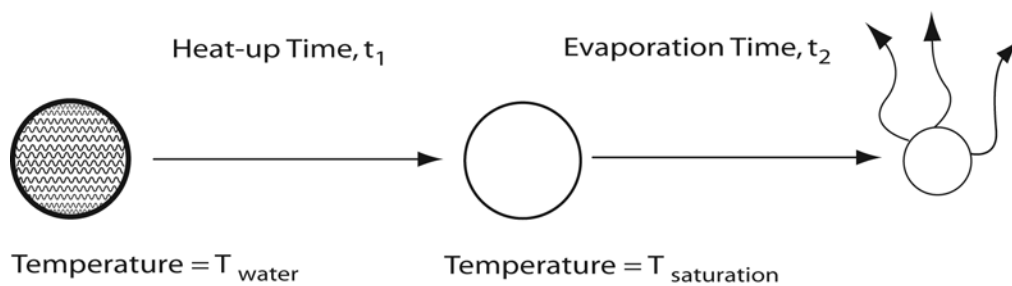

Figure 4:

Evaporation Process of a Water Droplet

The material break point, in the case where temperature reduction is a required design factor, is application specific and is not possible to advise as a rule of thumb process. The complexity of this calculation stems from the fact that the evaporation rate is a function of the following three variables.

- The enthalpy differential between the water and the saturation point determines the amount of time required, t_1 , for heating the water to its saturation point.
- The droplet diameter, which is a function of nozzle design and injection velocity, influences the amount of time required, t_2 , to evaporate the water once it becomes saturated.
- The length for proper evaporation is determined by multiplying the steam velocity by the sum of t_1 and t_2 .

Spray Water System Requirements

When selecting a spray water source the impact on both system turndown and operation cost must always be considered. Tradeoffs exist, especially when debating the added expense of a water pump versus using low-pressure spray water. The pressure differential between the water and the outlet steam dictates the operating range of the nozzle. The low-pressure water source severely limits the turndown and performance of a steam conditioning system, regardless of the upstream equipment supplied.

The design goal is to provide a water source that achieves the required turndown of the system, while minimizing the cost of operation. Some guidelines are provided in the following sections.

Water Pressure

When evaluating performance of a spray water source, it is important to remember that water passes through two stages of pressure drops. The first stage is the spray water control valve. This valve controls the

amount of water that is injected into the steam flow. The second stage is the spray nozzle. At this point, the spray water is broken down into a fine aerosol spray mist and introduced into the steam.

The availability of water pressure is paramount in the selection of the appropriate spray nozzles. This is because each nozzle design has a critical point where the pressure differential becomes too low and yields large slugs of water as opposed to the desired aerosol effect. Large slugs of water are ineffective in cooling the steam because their mass exceeds the limit of what the steam flow is capable of suspending. This results in poor cooling of the steam and severe water fallout. Other types of nozzles, such as variable orifice nozzles, require a minimum differential pressure that must be present to overcome the force on the nozzle and allow the flow passage to open.

When the minimum pressure limitations are satisfied the spray nozzle becomes effective in injecting a fine aerosol of water into the steam. When the minimum pressure limitations are surpassed, the nozzle is able to supply a larger capacity of spray water and supplies a larger range of turndown. The amount of available pressure differential above the minimum limit dictates the turndown range of the spray nozzle. This is explained in the following example application. In the example below, assume the use of a spray nozzle with $C_v = 1.0$. Also assume the specific gravity of the water is 1.0. This example compares two operating scenarios, the first uses a water source with an available pressure differential of 400 PSI, and the second uses a water source with an available pressure differential of 100 PSI. In both scenarios, assume the minimum effective pressure differential of the nozzle is 25 PSI.

The equation to calculate the C_v of an incompressible fluid such as water is:

$$C_v = Q \sqrt{\frac{SG}{\Delta P}}$$

Which can be rearranged to calculate the volume flow rate, Q (GPM):

$$Q = C_v \sqrt{\frac{\Delta P}{SG}}$$

Scenario 1: 4:1 Turndown Application

$$\begin{array}{l} Q_{\max} = 1.0 \sqrt{\frac{400}{1.0}} \\ Q_{\max} = 20 \text{ GPM} \end{array} \left| \begin{array}{l} Q_{\min} = 1.0 \sqrt{\frac{25}{1.0}} \\ Q_{\min} = 5 \text{ GPM} \end{array} \right.$$

Scenario 2: 2:1 Turndown Application

$$\begin{array}{l} Q_{\max} = 1.0 \sqrt{\frac{100}{1.0}} \\ Q_{\max} = 10 \text{ GPM} \end{array} \left| \begin{array}{l} Q_{\min} = 1.0 \sqrt{\frac{25}{1.0}} \\ Q_{\min} = 5 \text{ GPM} \end{array} \right.$$

The water source used for steam conditioning should be more than 150 PSI (11.5 Bar) above the outlet steam pressure. This range ensures proper atomization and a good range of performance. A higher water pressure differential is also desirable. Water pressure below 150 PSI is also acceptable, however, low-pressure differential limits the amount of turndown the system is able to provide. The minimum operating differential pressure is typically between 20 PSI and 45 PSI, depending on the nozzle design that is being used.

Each spray nozzle also has a maximum rated pressure differential. However, this is not a concern because the excess pressure differential is distributed across the water control valve.

Water Temperature

The temperature of the water source is a variable that directly impacts the amount of water required to reduce the steam to a specified outlet temperature. The water temperature also has a direct effect on the amount of downstream pipe that is required and dictates the efficiency of evaporation.

Cold water sources, such as condensate and makeup water, require less mass flow to sufficiently cool the steam to the outlet set point. The exact amount of water required can be determined through a heat balance calculation. This calculation is a balance of the quantity of heat entering the valve in the forms of inlet steam and spray water, to the quantity of heat exiting the valve as the outlet steam.

$$\dot{m}_{Inlet} * H_{Inlet} + \dot{m}_{Water} * H_{Water} = \dot{m}_{Outlet} * H_{Outlet}$$

This quantity is measured by flow rate, \dot{m} , and the heat is measured by enthalpy, H .

From the law of conservation of mass, we can substitute \dot{m}_{Outlet} with the combination of $\dot{m}_{Inlet} + \dot{m}_{Water}$.

$$\dot{m}_{Inlet} * H_{Inlet} + \dot{m}_{Water} * H_{Water} = (\dot{m}_{Inlet} + \dot{m}_{Water}) * H_{Outlet}$$

This equation can then be rearranged to solve for the water mass flow rate, \dot{m}_{Water} .

$$\dot{m}_{Water} = \dot{m}_{Inlet} * \left(\frac{H_{Inlet} - H_{Outlet}}{H_{Outlet} - H_{Water}} \right)$$

Hot spray water, such as boiler feedwater, requires a larger quantity of flow, but evaporates at a faster rate because less heat transfer is required to reach the saturation point. High temperature water also reduces thermal shock by minimizing the differential temperature between the steam and water.

For the majority of the cases, hot water is beneficial to steam conditioning as it minimizes the downstream pipe requirements and helps protect against water fallout. However, in low-pressure steam applications, hot water can sometimes result in flashing as the pressure is reduced through the control valve or nozzle orifice. If the flashing occurs upstream of the nozzle, special valve trim is required to prolong the active life of the equipment. If the flashing occurs upon injection into the outlet pipe, it will be beneficial in assisting with evaporation and mixing of the water with the steam.

The water temperature is a design condition that typically can not be modified for a particular application. However, it is important to understand the impact the water source has and design the system to suit the condition.

Strainers

The SteamForm spray water injection system is made up of a variety of nozzle types and sizes to ensure optimum results in a variety of applications. Available nozzle types include flat spray pattern nozzles, hollow-cone spray pattern nozzles, and variable orifice nozzles. Each nozzle is selected based on water quantity required and the available water pressure differential. These nozzles all possess a unique spray pattern and droplet size, which dictates the performance capabilities of the SteamForm.

Warning: Failure to install a strainer can result in blockage of the nozzle, damage to heat sensitive equipment, and plant shutdown.

To prevent blockage of these small orifice nozzles, an inline strainer is strongly recommended on all spray water lines. Regardless of the quality of the water source, the possibility always exists that scale, debris, or other pieces of particulate can be found in the water system. This particulate can be large enough to clog or block the flow exiting the nozzle.

The strainer must always be installed as close to the nozzles as possible to collect any possible scale or debris that can be in the water system. The recommended mesh size of the strainer varies with nozzle specifications, and can be found on the spray water analysis sheet provided with each SteamForm quotation or by contacting a Masoneilan factory representative. Strainers must be monitored and maintained periodically to ensure blockage does not occur.

Valve Installation

The steam conditioning valve is an instrumental piece of equipment used to prolong the active life of the plant and critical pieces of equipment. When properly used, the steam conditioning valve keeps a plant on-line during load rejections and allows the system to return to normal operation with minimized delays. It can also be used to protect sensitive downstream equipment from heat and pressure excursions or during the plant start-up phase.

To protect the plant and its equipment, it is important not to overlook the necessary steps that prolong the life of the steam conditioning valve. Several steps can be taken to ensure the valve is installed in the best possible orientation, and it is easily accessible for routine maintenance. The guidelines below are suggested to limit exposure to undesirable scenarios and prolong the useful life of the valve.

Valve Support

All valve supports must be mounted to fixed points within the piping system. Excess strain on the valve components must be avoided whenever possible. The SteamForm can never be used as a fixed point at which a system is mounted on. Supports must not be welded to the SteamForm valve body.

Actuator Support

Actuation support can become a concern in the case of horizontal actuation installations. When large actuators are mounted horizontally, a spring-loaded saddle support system must be used to cradle the actuator and minimize stress applied to the valve plug and stem. The saddle support system must be periodically monitored to verify the support is not out of its original tuning. If not properly maintained, the support system can become a source of additional stress on the actuator, plug, and stem.

Orientation

The proper orientation of the SteamForm valve is important to ensure efficient vaporization and mixing of the spray water. For best results, the recommended orientation is to install the valve with a horizontal inlet and a vertical flow down outlet, as shown in Figure 5. In this orientation, the vertical run of outlet pipe assists in mixing of the spray water by creating a flow path that is parallel to gravitational flow direction that the water is naturally pulled towards. This parallel direction assists by suspending the water within the steam flow while heat transfer is taking place and the water is evaporating.

On the contrary, in a horizontal outlet flow path heavier water droplets are encouraged by gravity to fallout of the steam flow and run along the bottom of the pipe. This results in flooding of the downstream steam lines and poor temperature control. This is particularly important for applications that need a wide range of turndown capability, as low velocity steam flows cannot maintain

enough momentum to properly suspend the water during this process.

When determining the orientation, it is important to address future maintenance considerations and the effects of condensate build up. If the SteamForm is mounted with a vertical flow up outlet as shown in Figure 6, the removal of trim and maintenance on the valve becomes extremely difficult. Another drawback is, the SteamForm valve body now acts as a condensate trap, being that the valve body is the low point of this system. Water fallout, in this system, becomes detrimental to the long-term success of the valve as water build-up occurs inside the trim and results in premature erosion.

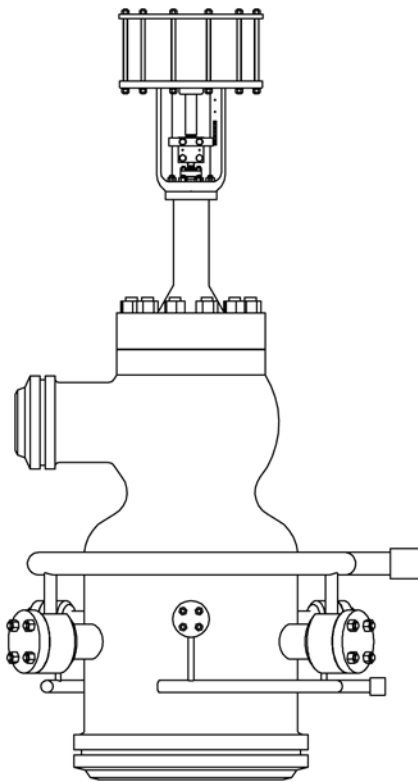

Figure 5:

Recommended orientation of the SteamForm

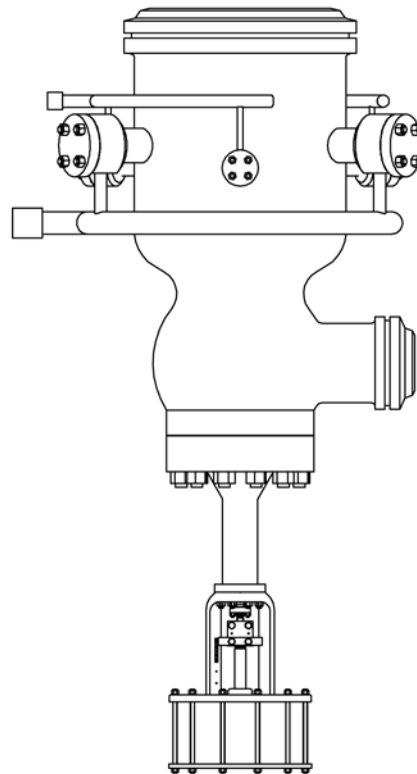

Figure 6:

Improper Orientation of the SteamForm

Drains and Pipe Slopes

The SteamForm valve must never be used as a condensate trap for the steam line. When condensate is passed through the trim of the SteamForm, flashing occurs as the condensate reacts to the pressure reduction. The flashing of the condensate erodes the surface of finished parts and can fragment the surface of the valve's diffuser. This is avoided by properly designing the piping system to slope away from the valve and installing drain connections at all low points of the piping system. Figures 7 through 10 show four possible installation scenarios and the desired location of drain connections to protect the SteamForm from passing condensate.

Drain connections can also be supplied by the factory for installation that result in the body of the SteamForm acting as the low point of the piping system. The locations of the SteamForm valve body drains are shown in Figures 9 and 10.

Drain connections must also be located at all downstream low points of the piping system to remove excess water that has fallen out of the steam flow during service. This preventative design will reduce the risk of water hammer induced damage.

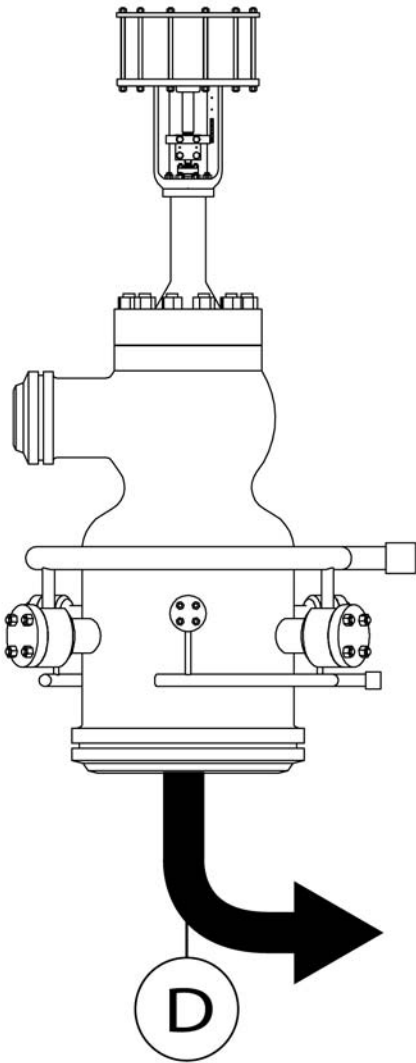

Figure 7:

Vertical Flow Down Outlet Orientation, Drain Should be Located at Low Point Downstream

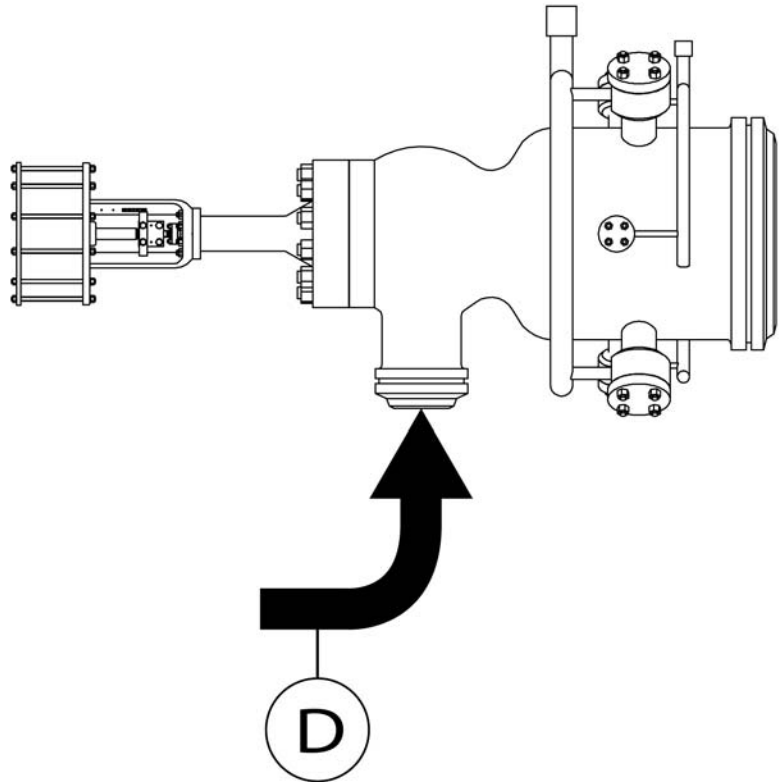
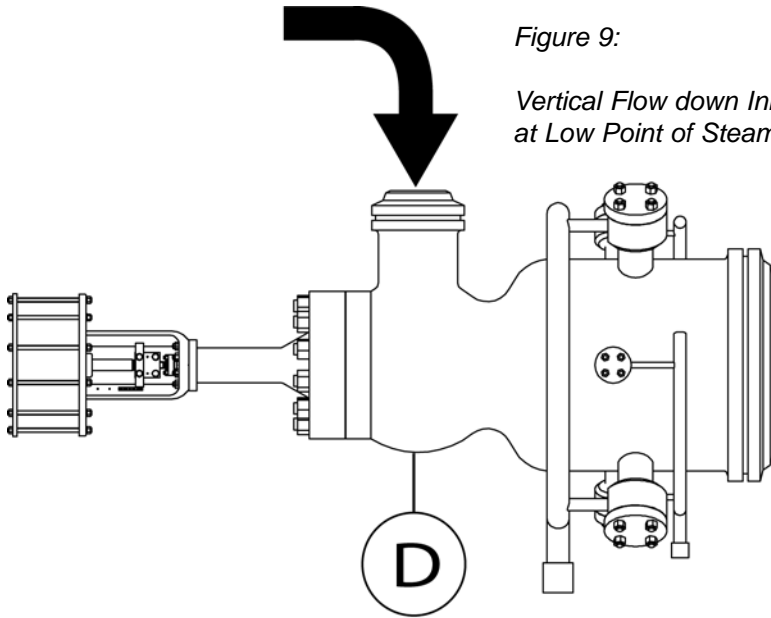

Figure 8:

Vertical Flow Up Inlet Orientation, Drain Should be Located at Low Point Upstream

Figure 9:

Vertical Flow down Inlet Orientation, Drain Should be Located at Low Point of SteamForm Valve Body.



Warning: Failure to install a condensate drain at all piping low points can result in flashing and water hammer damage to the SteamForm valve and surrounding system.

Figure 10:

Horizontal Inlet and Horizontal Outlet Orientation, Drain Should be Located at Low Point of SteamForm Valve Body.

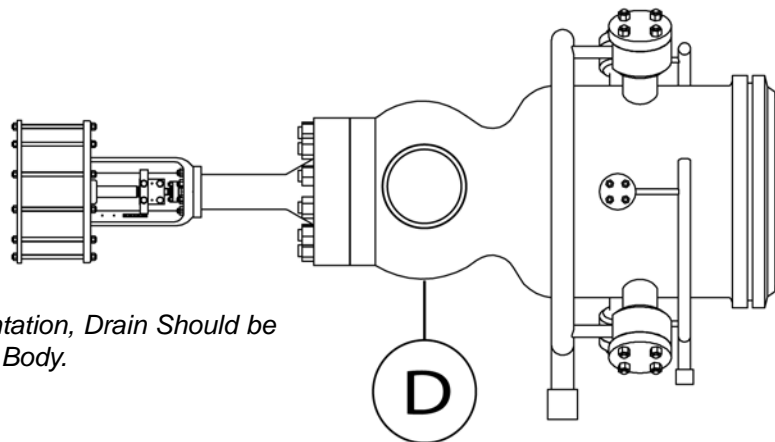

Warm-up and Preheating Steam

SteamForm valves that are designed for intermittent operation, such as turbine bypass applications, can be installed with a warm-up system to minimize the effects of thermal shock on the valve body and downstream piping. Thermal shock can occur when the valve sits idle for long periods of time and is instantly shocked when full load conditions of high temperature steam are forced through the valve upon an upset condition, such as a turbine trip.

These thermal shock scenarios occur when the steam conditioning valve is mounted farther than ten feet away from the main header. In this case, heat transfer to the valve is reduced making it possible for the valve body to cool to a large temperature differential compared to the live steam passing through it. To counter this condition, the SteamForm can be designed with warm-up bypass

connections to allow a minimal amount of live steam to flow through the valve body and maintain a consistent heat level at all times during non-operation of the valve.

By bleeding small quantities of steam from an upstream source, such as the main header, the possibility of thermal shock on the valve and system can be greatly reduced. These proactive measures require additional system costs, however they extend the active life of the steam conditioning valve and the surrounding system.

The design of this system can be flexible to meet the constraints of the plant. A Masoneilan factory representative can be contacted for an in depth evaluation of various design options and warm-up steam quantity recommendations.

Insulation

All SteamForm valves should be surrounded with thermal and acoustical insulation. The SteamForm bonnet and spray nozzle flanges must be accessible through the insulation for routine maintenance reasons.

Warning: Noise insulated within a system remains within a system and propagates downstream. To reduce the effects of downstream noise, sufficient downstream attenuating equipment must be designed within the system.

Accessibility

Larger SteamForm valves require two or more maintenance personnel to service the installation. To properly service and maintain the valve, adequate space must be provided. If the valve is not accessible from the ground level, a working platform must be provided around the valve as a safe workable area for maintenance engineers. A safe route must be carefully planned out in advance to satisfy the needs of a proper start-up and routine maintenance.

Temperature Control Methods

The SteamForm must always be designed around the most critical operating scenario. This can include intermittent operations such as plant start-up and load rejection scenarios or may be a steady-state operation such as a continuous application of a process plant. Regardless of the operating technique, the SteamForm temperature control methods must be considered along with the design of the valve for best control performance.

Temperature – Feedback Control

Temperature feedback control is the most common method for controlling the amount of spray water that is injected into the steam flow. This method requires the use of a downstream temperature sensor that relays a signal to a separate water control valve, to adjust the amount of water injected and achieve the desired downstream set temperature.

When using the feedback control method, it is essential that the temperature sensor is located downstream at a distance greater than or equal to the minimum required distance that is specified by the factory for the application. For more information on the proper location of the temperature sensor, please refer to the temperature sensor location section under the downstream pipe recommendations of this document.

Warning: Failure to provide adequate downstream pipe length prior to the temperature sensor will result in instability and inability to control temperature.

Temperature – Feedforward Control

The temperature sensor is a proven method of control, but this method requires a longer lag time as a signal must travel from a sensor to the control valve and must also allow for response time. Feedback control also requires a significant length of downstream pipe to ensure spray water is vaporized and has achieved an evenly distributed temperature profile. These requirements are not available for all SteamForm installations. For these instances, a feedforward control method is suggested.

The feedforward control method is achieved with a control algorithm and inherent steam tables that are programmed into the Distributed Control System (DCS). This algorithm is a heat balance calculation used to calculate the required amount of spray water based on upstream conditions and a specific downstream set point. The algorithm is programmed directly into the DCS to provide fast response temperature control. Masoneilan customizes an algorithm to the SteamForm valve flow characteristics for each application requiring this control technology.

Response Time and Stroke Speed

Response time is critical in preventing steam and condensate losses from the system due to lifting of safety valves. These system requirements are specified during the early stages of the plant design and must account for both the lag time of the temperature control system and the opening speed of the SteamForm valve.

The lag time resulting from the response of the temperature sensing system can be reduced through the use of a dual method control system. This dual method system uses a feedforward control algorithm to determine the amount of water required and provides faster acting temperature response. The addition of a temperature sensor to this system improves the accuracy of the temperature control by “trimming” the variability once the downstream profile stabilizes.

Stroke speed must be considered in this system, as rapid response time can not be achieved with all methods of actuation. Stroke speeds using a pneumatic controller are often limited to the 2–3 second ranges. For faster response time, the use of electro-hydraulic actuation can be considered. Please consult a Masoneilan Certified Technician for a recommendation for each application.

Start-up and Commissioning

In addition to specifying the steam conditioning valves, a start-up procedure must also be defined up front in the design process. Proper cleansing of the steam line and water lines is essential to ensuring performance when the plant becomes operational. Debris left in line can remove the machined finish from a shutoff surface or block the orifice of a control element or spray nozzle. To protect the integrity of the operational trim, Masoneilan strongly encourages the purchase of sacrificial start-up trim, that is used to divert debris away from all critical surfaces. Installation of the start-up trim is shown in Figure 11.

Figure 11:

Start-up Trim.

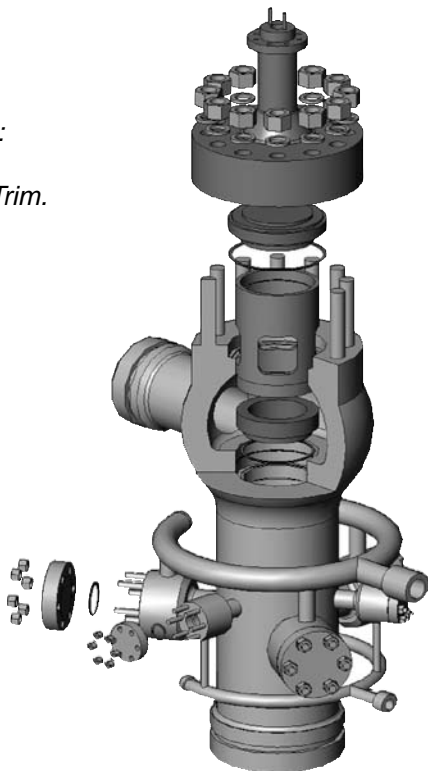

System Blow Down and Cleaning

With the SteamForm start-up trim installed and the spray nozzles removed, all debris, scale, and unintended substances must be flushed from the steam and water lines.

Conducting this cleaning procedure with operating trim installed can result in several possible scenarios requiring components replacement or repair. For instance, damage to a finished surface can result in premature erosion that eventually leads to unwanted leakage and unstable control. Debris lodged in the operating trim can also result in loss of flow capacity or plug sticking because of debris induced galling of the plug against a control surface.

Warning: Do not install operational trim and spray nozzles until the pipelines have been completely blown down and thoroughly cleaned. All debris must be removed to protect the trim from damage.

Post Weld Heat Treatment and Hydro-Testing

SteamForm valves are manufactured with either flanged or butt weld end connections. For valves that require welding into line, select welding rod that is compatible with the valve connection material. Check the valve specification sheet data for the body and end connection material that is being supplied.

The applicable codes of the country or state of installation specify welding and post weld heat treatment requirements that must be followed. Verification of localized welding temperatures by thermocouples is advised.

Warning: Removing the operational trim during these procedures is recommended to ensure the trim is not damaged.

Hydro-testing procedures can require a factory designed test fixture, depending on whether or not the SteamForm is used as a material or pressure class break point. In this type of installation, isolation of the inlet section from the outlet section is necessary to test each component individually against its unique code required testing conditions.

SteamForm Assembly

The SteamForm must be installed in line so the flow through the valve follows the direction indicated on by the flow arrow on the valve body.

After the steam lines are thoroughly cleaned and hydro-tested, it is safe to install the operating trim. For start-up assistance from a certified technician, please contact your local Masoneilan sales office or factory. For the complete installation procedure, please refer to the SteamForm instruction manual.

Commissioning Spares

A full set of commissioning spares should be available on site at all times to minimize the amount of downtime for the SteamForm. Commissioning spares must include, at a minimum, a full set of gaskets and packing to provide the required soft-parts for re-assembly.

Soft-parts such as gaskets and packing should never be re-used once they are removed from a valve. Do not interchange components with parts supplied for other valves.

Turbine Bypass to Condenser Applications

Several internal and external factors are introduced within the turbine bypass applications, specifically in the bypass to condenser application. The role of the SteamForm becomes critical in ensuring equipment is protected during the high pressure and temperature excursions. Another major concern is for the limitation of noise as high-energy steam is injected into a thin wall duct that acts similar to a noise amplifier. These concerns are addressed in more detail in the following sections.

Bypass System Requirements

The bypass to condenser design requires a significant reduction in the heat level of the steam to reach an enthalpy limit that is within the condenser design limitations. Heat limits require the SteamForm to reduce the steam temperature to the saturation range prior to admission into the condenser. This application also requires fast response to ensure safety valves remain closed and prevent steam from venting outside of this closed loop system.

Process Control

Controlling temperature at or near saturation is difficult due to the performance limitations of temperature sensing technology. If the steam passing the sensor is “wet”, the sensor recognizes water and signals that the steam is already sufficiently cooled. Wet steam is difficult to accurately measure and creates instability and large swings of process variability.

When reducing steam temperature to saturation, large quantities of water are injected. Large percentages of water over steam can result in flooding in the pipeline, and possible severe water fallout. The longer the distance that the water travels, the greater the risk becomes of water fallout and flooding. To limit this occurrence, close coupling of the SteamForm with a back-pressure dump tube is recommended. This close-coupled scenario forces the unvaporized water through the pressure reducing dump tube and assists in mixing by creating a low-pressure region that causes the water to instantly flash into steam. This process requires the use of feedforward control to maintain a stable and accurate downstream temperature set point.

Back-Pressure Dump Tubes

The back-pressure dump tube is an essential piece of equipment for the design of this bypass system. The pressure drop of this device must be strategically split to manage a balance between equipment size and cost compared to overall performance of the system. By properly staging the pressure drop the dump tube, SteamForm, and adjoining pipe sizes can all be minimized. This reduces the total cost of the installation.

The size of the dump tube becomes critical when inserted into the duct of an air-cooled condenser. Large dump tubes create an obstruction to the cross flow of the steam that is exhausting from the turbine prior to admission into the system condenser. The obstruction creates unwanted back-pressure on the turbine and reduces the overall efficiency of the turbine and steam plant. However, the dump tube must reach a certain size in order to space the holes of the tube and maintain steam jet independence for minimize noise generation.

Correctly staging the pressure drop in this system is essential in minimizing the noise generation and the cost of the installation. For specific design recommendations, it is essential to involve the bypass valve supplier and the condenser supplier up-front in the design stage to ensure the best design is provided for the interaction of equipment.

System Noise Evaluation

Noise in this system is created from the combination of multiple sources. The control valve, dump tube, and condenser duct are all potential sources for noise generation. Acoustical insulation is recommended for protecting pipe segments from excessive noise generation; however, noise insulated within a closed system propagates downstream until a noise attenuating device is installed. As noise propagates farther downstream, it eventually reaches the point where it is released into the thin walled duct of the condenser. At this point, the duct acts as a noise amplifier and increases the decibel level. Whenever possible, Masoneilan highly recommends surrounding all thin walled duct with acoustical insulation.

A further challenge is presented in a case where multiple bypass lines are all discharged into a single point of injection. Jet streams exhausting from the dump tubes can combine noise sources and create a single source that generates much higher levels of noise. To reduce noise levels, these jets must remain independent by installing large distances between each dump tube.

Noise levels in bypass to condenser applications have been measured in excess of 110 dBA. For best results, pre-installation concerns must be thoroughly evaluated by the design firm and the supplier of the turbine bypass equipment.

Final Recommendations

Severe service SteamForm applications have several specific design features that require detailed evaluation and consideration. Every hour spent in the design process can save days of downtime and dollars of maintenance cost. For each of these applications, it is recommended to contact a Masoneilan Certified Technicians to assist in evaluation and to provide application specific recommendations for long-term, successful operation.

SALES OFFICE LOCATIONS

BELGIUM

Dresser Valves Europe
281-283 Chaussée de Bruxelles,
1190 Brussels, Belgium
Phone: +32-2-344-0970
Fax: +32-2-344-1123

BRAZIL

Dresser Industria E Comercio Ltda
Divisao Masoneilan
Rua Senador Vergueiro, 433
09521-320 Sao Caetano Do Sul
Sao Paulo, Brazil
Phone: 55-11-453-5511
Fax: 55-11-453-5565

CANADA

Alberta
Dresser - Masoneilan
DI Canada, Inc.
Suite 1300, 311-6th Ave., S.W.
Calgary, Alberta T2P 3H2, Canada
Phone: 403-290-0001
Fax: 403-290-1526

Ontario
Dresser - Masoneilan
DI Canada, Inc.
5010 North Service Road
Burlington, Ontario L7L 5R5, Canada
Phone: 905-335-3529
Fax: 905-336-7628

CHINA

Dresser Flow Control, Beijing Rep. Office
Suite 2403, Capital Mansion
6 Xinyuannan Rd. Chaoyang District
Beijing 100004, China
Phone: +86-10-8486-5272
Fax: +86-10-8486-5305

FRANCE

Dresser Produits Industriels S.A.S.
4, place de Saverne
92971 Paris La Défense Cedex, France
Phone: +33-1-4904-9000
Fax: +33-1-4904-9010

Dresser Produits Industriels S.A.S.,
Masoneilan Customer Service Centre
55 rue de la Mouche, Zone Industrielle
69540 Irigny, France
Phone: +33-4-72-39-06-29
Fax: +33-4-72-39-21-93

GERMANY

Dresser Valves Europe GmbH
Heiligenstrasse 75
Viersen D-41751, Germany
Phone: +49-2162-8170-0
Fax: +49-2162-8170-280

Dresser Valves Europe GmbH
Uhlendstrasse 58
60314 Frankfurt, Germany
Phone: +49-69-439350
Fax: +49-69-4970802

INDIA

Dresser Valve India Pvt. Ltd.
305/306, "Midas", Sahar Plaza
Mathurdas Vasanti Road
J.B. Nagar, Andheri East
Mumbai, 400059, India
Phone: +91-22- 8381134
Fax: +91-22-8354791

Dresser Valve India Pvt. Ltd.
205, Moha Building
4 Bhikajji Cama Place
New Delhi, 110 066, India
Phone: +91-11-6164175
Fax: +91-11-6165074

ITALY

Dresser Italia S.r.l.
Masoneilan Operations
Via Cassano, 77
80020 Casavatore, Napoli Italy
Phone: +39-081-7892-111
Fax: +39-081-7892-208

JAPAN

Niigata Masoneilan Co. Ltd. (NIMCO)
20th Floor, Marive East Tower
WBG 2-6 Nakase, Mihama-ku,
Chiba-shi, Chiba 261-7120 Japan
Phone: +81-43-297-9222
Fax: +81-43-299-1115

KOREA

Dresser Korea Inc.
2015 Kuk Dong Building 60-1
3-Ka, Choongmu-ro Chung-Ku
Seoul, Korea
Phone: +82-2-2274-0792
Fax: +82-2-2274-0794

KUWAIT

Dresser Flow Solutions
Middle East Operations
10th Floor, Al Rashed Complex
Fahad Salem Street, P.O. Box 242
Safat, 13003, Kuwait
Phone: +965-9061157
Fax: +965-3718590

MALAYSIA

Dresser Flow Solutions
Business Suite, 19A-9-1, Level 9
UOA Centre, No. 19, Jalan Pinang
50450 Kuala Lumpur, West Malaysia
Phone: +60-3-2163-2322
Fax: +60-3-2161-1362

MEXICO

Dresser Valve de Mexico, S.A. de C.V.
Henry Ford No. 114, Esq. Fulton
Fraccionamiento Industrial San Nicolas
54030 Tlalnepanitla Estado de Mexico
Phone: 52-5-310-9863
Fax: 52-5-310-5584

THE NETHERLANDS

Dresser Valves Europe
Steenhouwerstraat 11
3194 AG Hoogvliet, The Netherlands
Phone: +31-10-438-4122
Fax: +31-10-438-4443

NIGERIA

Dresser Flow Solutions
Plot 293, Akin Olugbade Street
Victoria Island, Lagos, Nigeria
Phone: +234-1-555-4229
Fax: +234-1-555-7969

RUSSIA

DS Controls
Nekhinskaya Street, 61
Veliky Novgorod
Russia, 173021
Phone: +7-8162-11-3099
Fax: +7-8162-11-2981

SAUDI ARABIA

Dresser AL Rushaid
Valve & Instrument Co., Ltd. (Darvico)
P.O. Box 10145
Jubail Industrial City 31961, Saudi Arabia
Phone: +966-3-341-0278
Fax: +966-3-341-7624

SINGAPORE

Dresser Singapore PTE Ltd.
16 Tuas Avenue 8
Singapore 639231
Phone: +65-6-861-6100
Fax: +65-6-861-7197

SOUTH AFRICA

Dresser Limited
P.O. Box 2234
16 Edendale Road
Eastleigh, Edenvale 1610
Republic of South Africa
Phone: +27-11-452-1550
Fax: +27-11-452-6542

SPAIN

Masoneilan S.A.
C/Murcia 39 C
08830 Sant Boi de Llobregat
Barcelona, Spain
Phone: +34-93-652-6430
Fax: +34-93-661-3450

UNITED ARAB EMIRATES

Dresser Flow Solutions
Middle East Operations
P.O. Box 61302
Roundabout 8
Units JA01 & JA02
Jebel Ali Free Zone
Dubai, U. A. E.
Phone: +971-4-8838-752
Fax: +971-4-8838-038

UNITED KINGDOM

DI U.K. Ltd.
East Gillibrands
Skelmersdale,
Lancashire WN8 9TU, England
Phone: +44-1695-52600
Fax: +44-1695-50569

DI U.K. Ltd.

Unit 4, Suite 1.1, Nobel House
Grand Union Office Park
Packet Boat Lane
Uxbridge, Middlesex UB8 2GH
Phone: +44-1895-454-900
Fax: +44-1895-454-917

UNITED STATES

Northern Region
Dresser -Masoneilan
85 Bodwell Street
Avon, MA 02322-1190
Phone: 508-586-4600
Fax: 508-427-8971

South Texas Operations
Dresser - Masoneilan
4841 Leopard Street
Corpus Christi, TX 78408-2621
Phone: 361-877-2414
Fax: 361-584-1196

Western Region
Dresser - Masoneilan
Masoneilan
2950 East Birch Street
Brea, CA 92821
Phone: 714-572-1528
Fax: 714-572-1463